



# PW-310MA

Compact gas flushed MAP packaging machine



*Searching for a New Balance*

## Dimensions

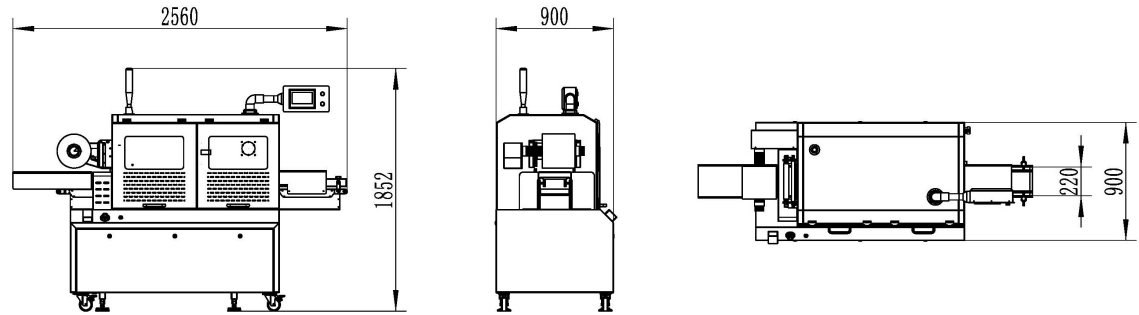

## Specifications

<b>Name</b>		<b>PW-310MA</b>
<b>Packaging Type</b>		<b>Gas Flush MAP, Seal Only</b>
<b>Packaging Item</b>		<b>Tray</b>
<b>Packaging Speed</b>		<b>Cycles/min MAP: 10-12</b> <b>Cycles/min SEAL ONLY: 12-15</b>
<b>Power Supply</b>		<b>AC 220V/100V</b>
<b>Power Consumption</b>		<b>3.5 kW</b>
<b>Film</b>	<b>Film Material</b>	<b>Composite Film</b>
	<b>Film Width(mm)</b>	<b>Max. 250</b>
	<b>File Thickness</b>	<b>25 μ</b>
	<b>Diameter of Film Roll(mm)</b>	<b>Max. 260</b>
	<b>Core Diameter of Film Roll(mm)</b>	<b>76</b>
<b>Tray</b>	<b>Mold</b>	<b>1 set of die</b>
	<b>Size of Packed Tray (L mm x W mm)</b>	<b>Max. 260 x 177</b> <b>Min. 180 x 120</b>
<b>Machine Weight(kg)</b>		<b>683</b>
<b>Machine Size(L mm x W mm x H mm)</b>		<b>2560*900*1852</b>

## Option

Automatic weigh-label system : LI5600A



Weighing*		Interval type	Multi-interval	Single-interval
Capacity			Max 3/6kg	Max 6/15kg
Scale interval			e=1/2g	e=2/5g
Weighing range			2-g-6kg	40g-15kg
Conveyor capacity			Max 6kg	Max 15kg
Label Type			Linerless	Die-cut
Label Size	Automatic application	Width	44-78mm/1.73-3.07inches	40-80mm/1.57-3.15inches
		Length	28-105mm/1.10-4.13inches	28-105mm/1.10-4.13inches
	Manual application	Width	44-78mm/1.73-3.07inches	40-80mm/1.57-3.15inches
		Length	20-500mm/0.79-19.69inches* <small>*Max printing length is 300mm/11.8inches</small>	20-150mm/0.79-5.91inches
Labeling angle		0 or 90 or 180 or 270 degree		
Dot density		12 dot/mm(300dpi)		
Font		True type font		
Display Panel		TFT LCD color(15inches) touch panel		
Memory for programmable files		32GB		
Power source and power consumption		Scale Conv: 230V;1φ;50/60Hz;0.7A;160W Labelling Conv: 230V;1φ;50/60Hz;0.9A;165W		

\*Specifications are subject to change without prior notice.

SHANGHAI TERAOKA ELECTRONIC Co., Ltd.

TINGLIN INDUSTRY DEVELOPMENTAL ZONE,  
JINSHAN COUNTY, SHANGHAI 201505  
TEL: +86-21-57234888  
FAX: +86-21-57233049  
<http://www.digisystem.com.cn>